

DRAWSTRING BAG

INSTRUCTIONS FOR MAKING A DRAWSTRING BAG WITH A CONTRAST CORD CHANNEL.
SEAM ALLOWANCE IS 1CM UNLESS STATED OTHERWISE.

SKILL LEVEL: BEGINNER

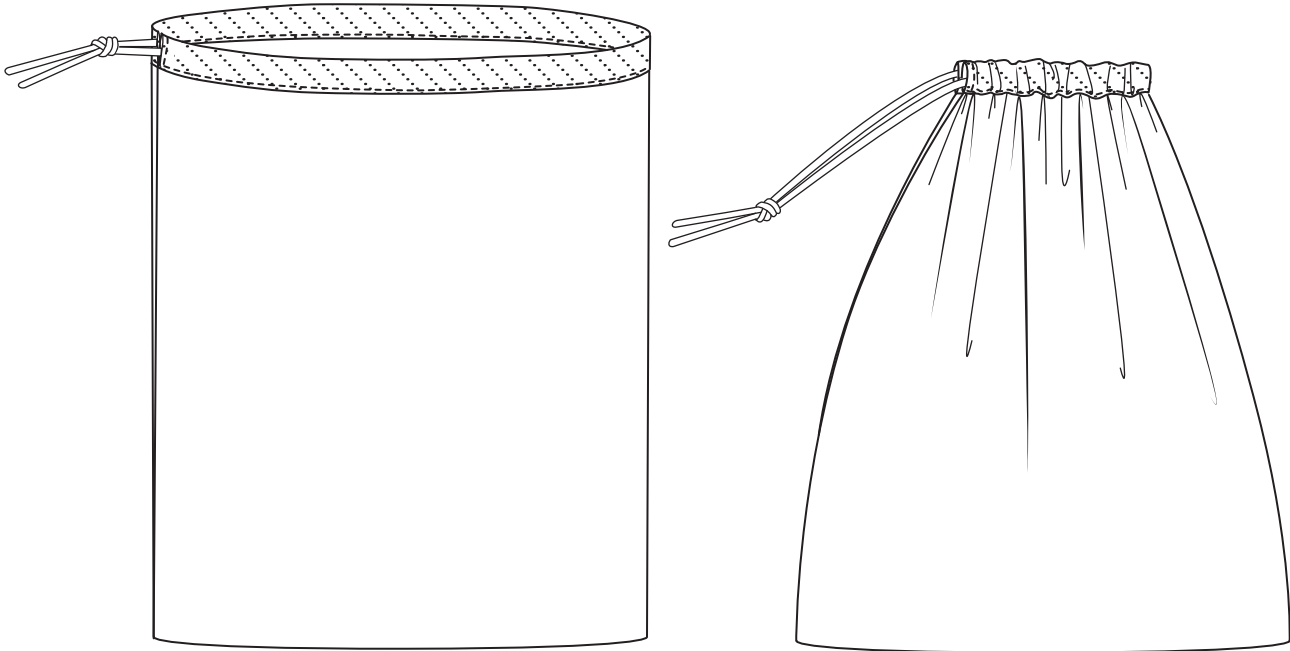

FINISHED MEASUREMENTS

WIDTH 47cm/18½"

LENGTH Half width of fabric, plus 2cm/¾"

SUGGESTED FABRIC

3-12 OZ LINEN, BRUSHED COTTON,
INDIAN HANDLOOMS, COTTON BLOCK
PRINTS, HEMP BLENDS, WOOL,
COTTON CORDUROY & NEEDLECORD.

YOU WILL NEED

SELF: 50cm/19¾" x width of fabric

CONTRAST: 8cm/3¼" x 97cm/38¼"

MATCHING THREAD

CORD OR FABRIC SCRAP FOR DRAWSTRING x 120cm/47¼"

OPTIONAL: EMBROIDERY THREAD

FABRIC KEY

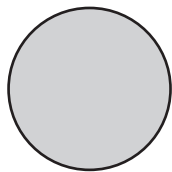

RIGHT SIDE
SELF

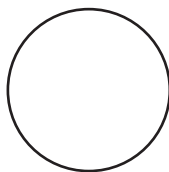

WRONG SIDE
SELF

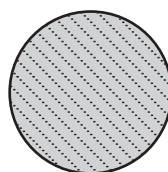

RIGHT SIDE
CONTRST

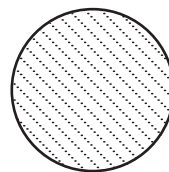

WRONG SIDE
CONTRAST

MERCHANT & MILLS

EMBROIDERY TEMPLATE

This is the embroidery template for our drawstring bag (optional).



BACK STITCH

For the writing we used **BACK STITCH** as follows: Fasten thread and bring to the right side. Working from right to left, each stitch is made backwards to meet the preceding one as shown.

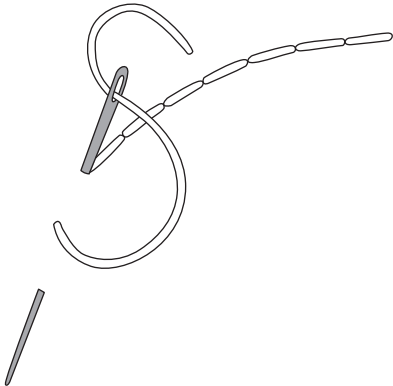

CHAIN STITCH

For the circle we used **CHAIN STITCH** as follows: Fasten thread and bring to the right side. Working from right to left. Loop the thread up and around. *Insert the needle just behind the point where thread emerges and bring it up, over the looped thread, a stitch length in front of that point. Pull thread through to the left to form a looped stitch. Repeat from *

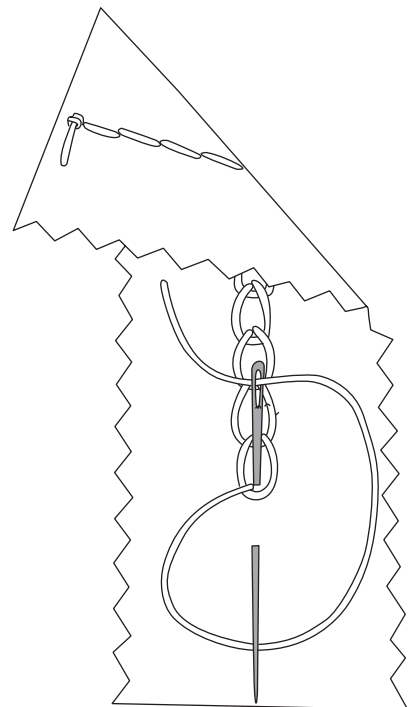

DRAWSTRING BAG

INSTRUCTIONS

Instructions for making a drawstring bag with a contrast cord channel.
Seam allowance is 1cm unless stated otherwise.

Skill level: Beginner

CUTTING FORMULA

1. For our drawstring bag we have used the whole width of the fabric to provide the bag length (shown fabric 110cm wide). If a shorter bag length is required you can cut down to the desired length.

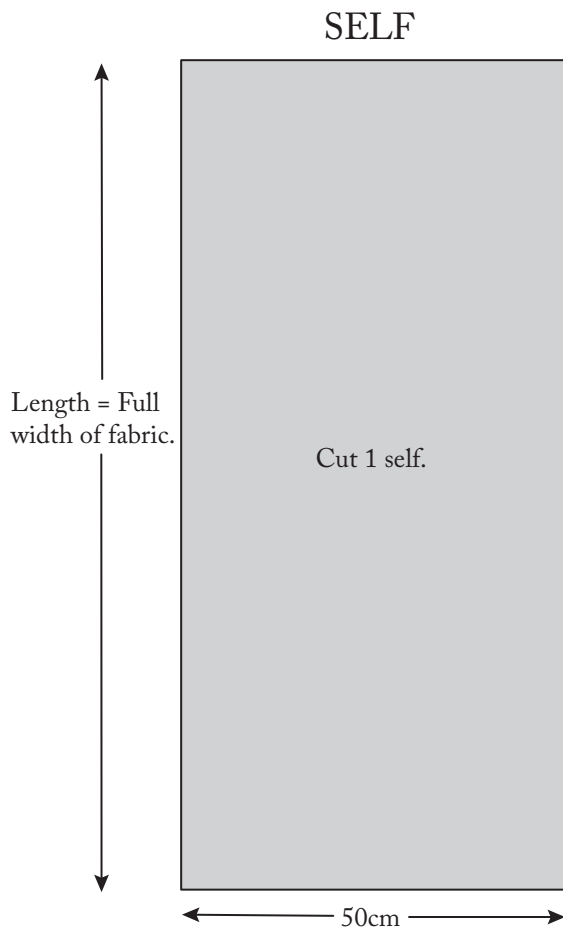

CONTRAST

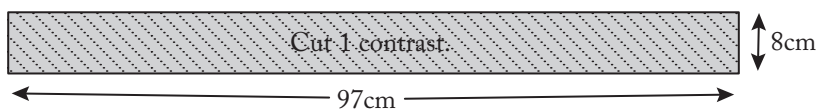

EMBROIDERY (OPTIONAL)

2. Place the template 12cm up from the half way point and centred in the width. Mark the template using one of the following options:
 - For fine fabrics, tape the template to a **window** or **light box** and trace through the design with a pencil or water soluble pen.
 - The template can be printed directly onto **water-soluble stabilizer**, then placed onto your fabric. After stitching through the fabric and stabilizer, soak the embroidery in warm water and the stabilizer dissolves away.
 - Using carbon or wax **transfer paper/dressmaker's carbon paper**, lay the fabric face-up on a hard surface. Place the transfer paper over the fabric having the waxy ink toward the fabric. Then place the template on top of the transfer paper. Pressing hard with a stylus or empty ball-point pen, transfer the design to the fabric.
 - Trace your pattern onto lightweight **tracing paper**. Tack the paper onto your fabric and then embroider through the paper and fabric. When finished, carefully tear away the tracing paper.
- N.B. On fine fabrics it is advisable to back the embroidery with interfacing. Using an embroidery ring will help to prevent the fabric gathering in.

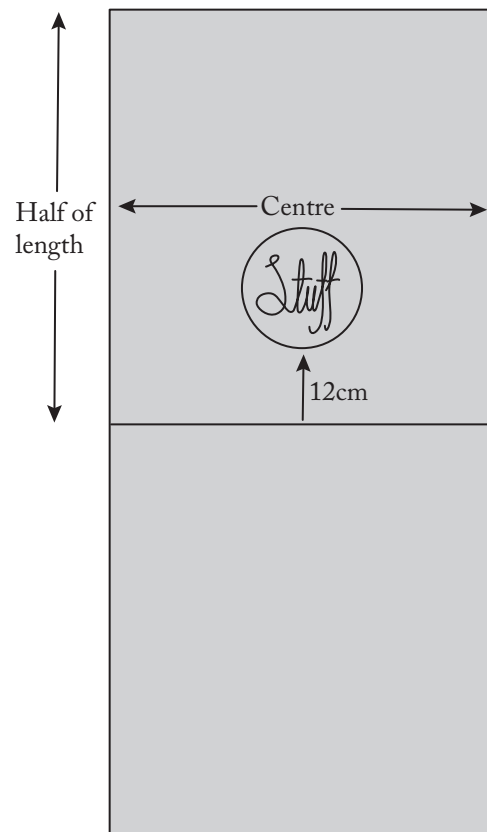

SIDE SEAMS

3. Work french seams as follows: With wrong sides together fold the self piece in half lengthwise. Stitch side seams with a 0.5cm seam allowance, stopping one side 1cm away from the top.

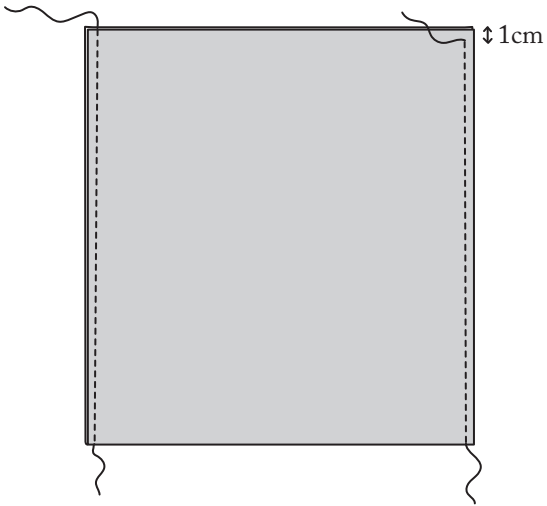

4. Turn to the wrong side and press. Stitch 1cm from the pressed seam, sandwiching in the previous seam, stopping 1cm away from the top (the side where stitching ended 1cm from the top previously).

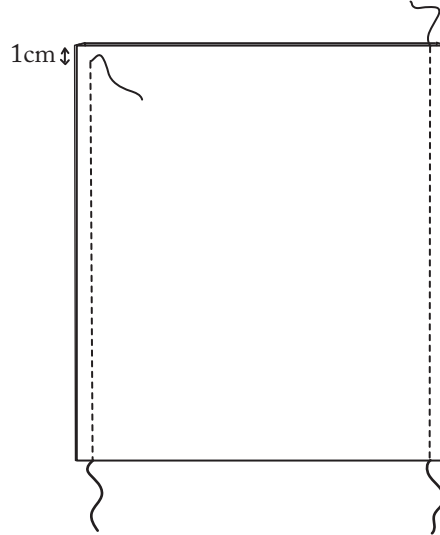

Turn to the right side and press.

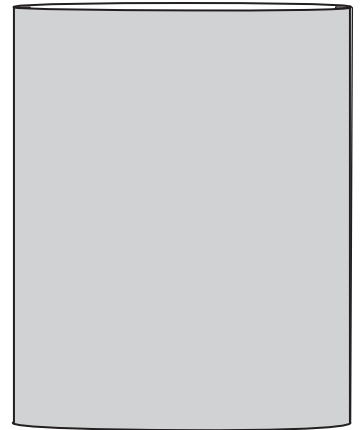

CREATE DRAWSTRING CASING

5. Turn in both short edges of the contrast by folding in the edges by 1cm (twice). Press and edgestitch down.

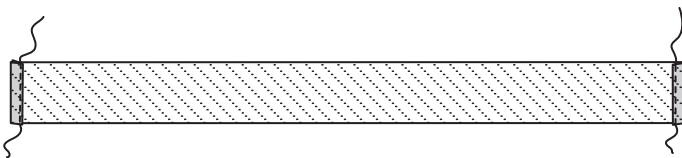

6. Turn in one long edge by 1cm and press.

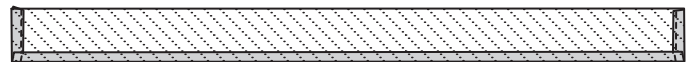

7. With right sides together and matching folded short edges to the side seam with the gap (the side where stitching ended 1cm from the top) stitch casing to top of bag.

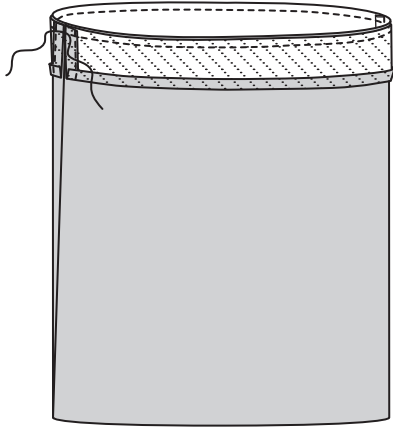

8. Fold over the casing so that the previously pressed folded edge covers the seam and tack.

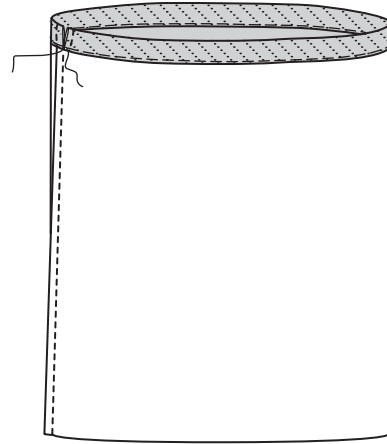

9. Turn bag to the right side and edgestitch. Remove tacking.

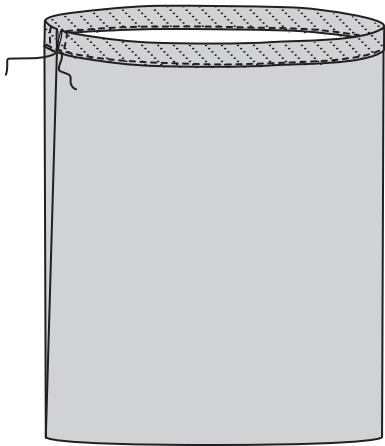

THREAD DRAWSTRING

10. Thread the drawstring through the channel and knot the drawstring together.

