

# HOT WATER BOTTLE COVER

A CLASSIC HOT WATER BOTTLE COVER. MAKE IT LINED OR UNLINED, BAGGED OUT OR BOUND.

SKILL LEVEL: INTERMEDIATE

BOUND VERSION (LINED OR UNLINED)

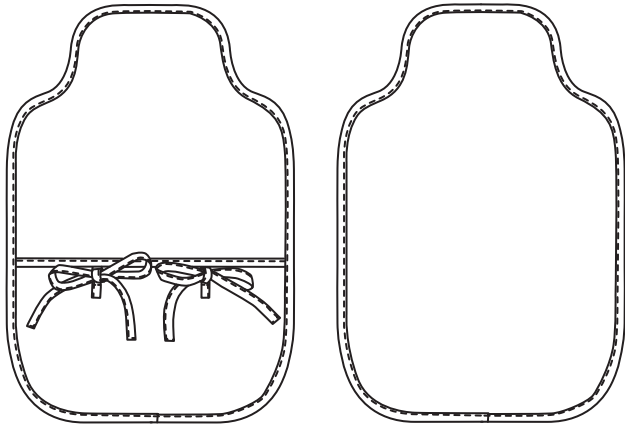

BAGGED OUT VERSION (LINED OR UNLINED)

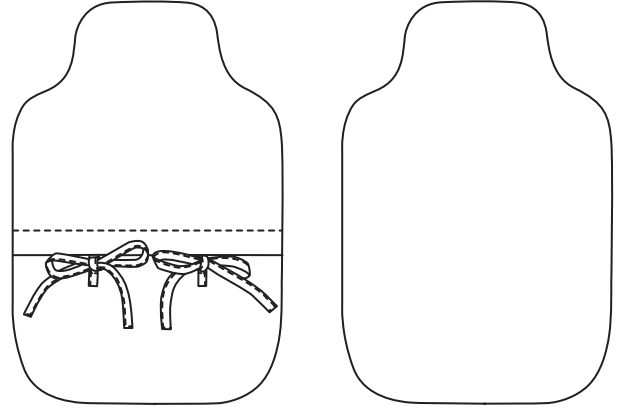

## FINISHED MEASUREMENTS

LENGTH	36cm/14¼"
WIDTH	24cm/9½"

## SUGGESTED FABRIC

LINEN, 7-12OZ/237-414GSM DENIM, WOOL, CORDUROY, QUILTED JACQUARD AND QUILTED COTTON. FOR LININGS - COTTON VOILE, LIGHTWEIGHT LINEN, COTTON POPLIN, LIGHTWEIGHT WOOL AND SLIP LININGS.

## YOU WILL NEED

MATCHING THREAD  
0.4M/½YD SELF  
0.4M/½YD LINING (OPTIONAL)  
CONTRAST FABRIC FOR TIES (OPTIONAL):  
13CM/5¼" X 24CM/9½"  
BIAS BINDING (OPTIONAL) 3.5CM/1½" X 1.7M/2YD

MERCHANT & MILLS

# Before you begin!

## PRINTING

Please print your pattern at 100%, DO NOT SCALE to fit paper. Before printing pattern, print out this page and measure the test square. The square should measure 10 x 10 cms (some printers will be different - experiment with the scale to get the square exactly 10cm).

**HOT WATER BOTTLE COVER**  
A CLASSIC HOT WATER BOTTLE COVER. MAKE IT LINED OR UNLINED. BAGGED OUT OR BOUND.  
SKILL LEVEL: INTERMEDIATE

ROUND VERSION (LINED OR UNLINED)      BAGGED OUT VERSION (LINED OR UNLINED)

**FINISHED MEASUREMENTS**  
LENGTH: 36cm/14"  
WIDTH: 24cm/9"

**SUGGESTED FABRIC**  
LENING - 100% COTTON OR 60% COTTON/40% LINEN  
WOOL, CORDUROY, QUILTED, FLEECE AND HEAVY COTTON.  
FOR LINED - COTTON VOILE, LIGHTWEIGHT LINEN, COTTON POPLIN, LIGHTWEIGHT WOOL AND SUPPLINGS.

**YOU WILL NEED**  
MATCHING THREAD  
6-8MM ZIPPER  
6-8MM LENSING (OPTIONAL)  
CONTRAST FABRIC FOR TIES (OPTIONAL)  
12CM/5" BIAS BINDING (OPTIONAL) 1.5CM/5/8" X 1.7M/2YD

MERCHANT & MILLS

Printer: Canon iP4800 series 2  
Presets: Default Settings  
Copies: 1  
Pages: All  
Paper Size: A4 210 by 297 mm  
Orientation: Portrait  
Scale: 100%  
Copies per page: 1

PDF Hide Details Cancel Print

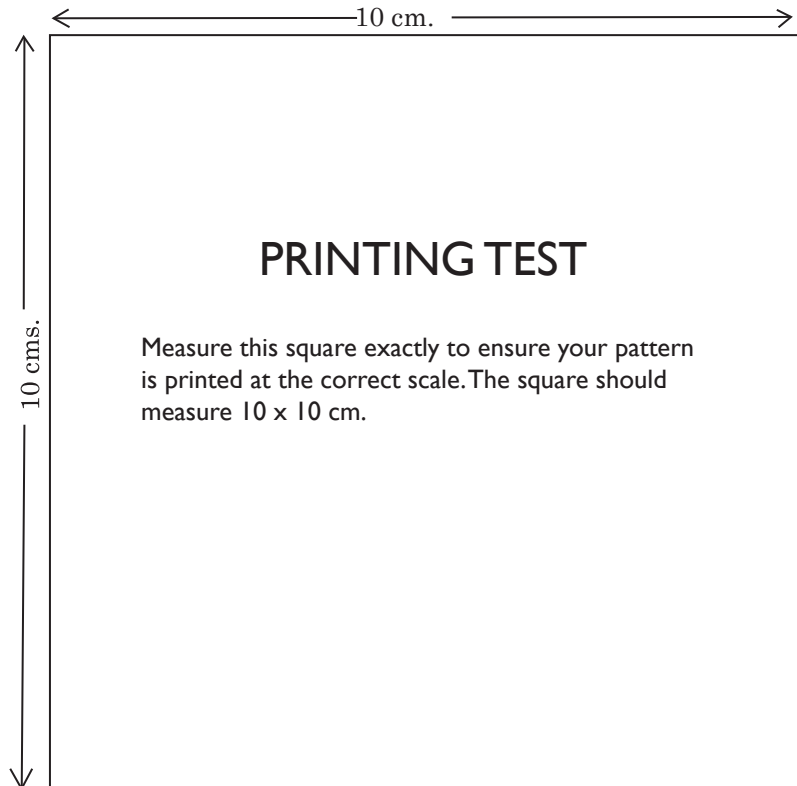

NOTCH  
CENTRE

1

FRONT  
CUT 1 ON FOLD SELF  
& CUT 1 ON FOLD LINING (OPTIONAL)

HOT WATER BOTTLE COVER  
**MERCHANT & MILLS**  
SEWING PATTERN

PLACE ON FOLD

TAPE TO LINE B

LINE A

LINE A

HOT WATER BOTTLE COVER  
**MERCHANT & MILLS**  
SEWING PATTERN



TIE  
CUT 4 SELF OR CUT 4 CONTRAST

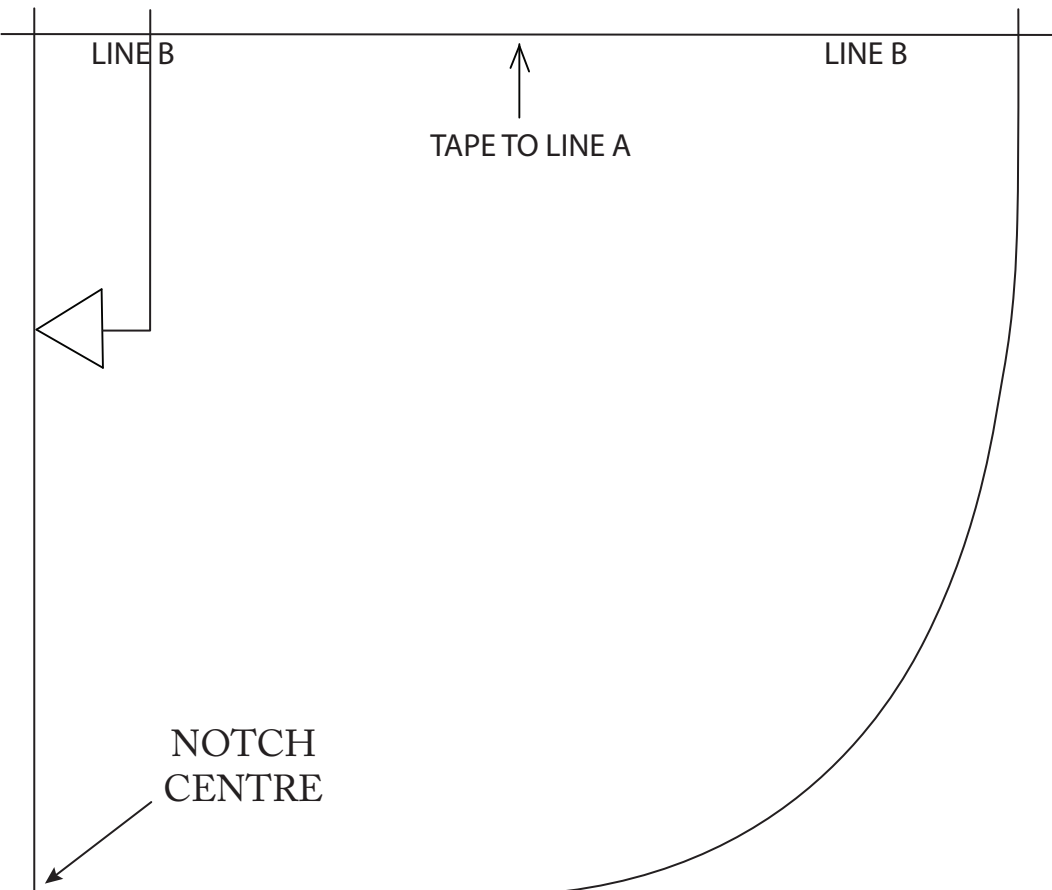

NOTCH  
CENTRE

PLACE ON FOLD

3

BACK TOP  
CUT 1 ON FOLD SELF  
& CUT 1 ON FOLD LINING (OPTIONAL)

HOT WATER BOTTLE COVER  
**MERCHANT & MILLS**  
SEWING PATTERN

TIE  
POSITION  
(BOUND)

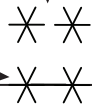

CUT HERE FOR  
BOUND VERSIONS

TIE  
POSITION  
(LINED)



CUT HERE FOR LINED VERSION

TIE  
POSITION  
(UNLINED)



CUT HERE FOR LINED VERSION

FOLDLINE

CUT HERE FOR BOUND VERSIONS

# HOT WATER BOTTLE COVER

## **MERCHANT & MILLS**

### SEWING PATTERN

PLACE ON FOLD

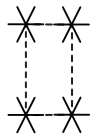

TIE POSITION

# 2

BACK LOWER  
CUT 1 ON FOLD SELF  
& CUT 1 ON FOLD LINING (OPTIONAL)

NOTCH  
CENTRE

# HOT WATER BOTTLE COVER

## INSTRUCTIONS

A classic hot water bottle cover. Make it lined or unlined, bagged out or bound. Seam allowance is 1cm, unless stated otherwise.

Skill level: Intermediate

### MAKE TIES

1. Press in 1cm at one end of the TIES (4).

Press in the two long edges to the centre.

Fold the in half, lengthways and edgestitch together.

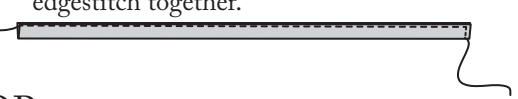
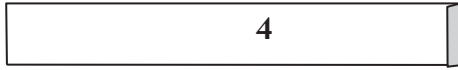

### ATTACH TIES ON BACK TOP

2. With right sides together, place the raw edges of the TIES (4) where indicated by tailor tacks on the edge of the BACK TOP (3). Stitch 0.9cm away from the edge.

On the bound version place the right raw edges of the right side of the TIES (4) where indicated by tailor tacks on the edge of the wrong side of the BACK TOP (3). Stitch 0.9cm away from the edge.

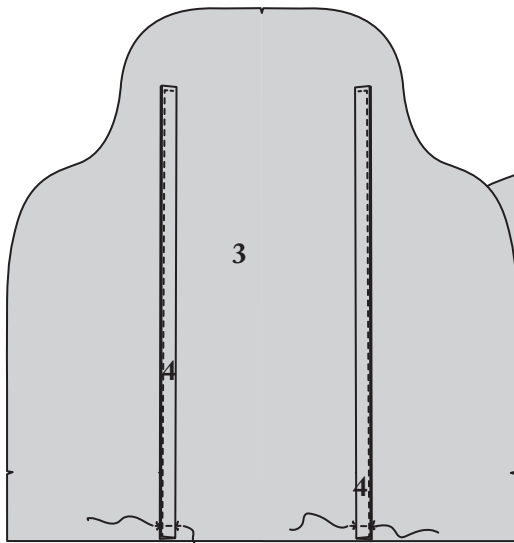

*Shown: Unlined version.*

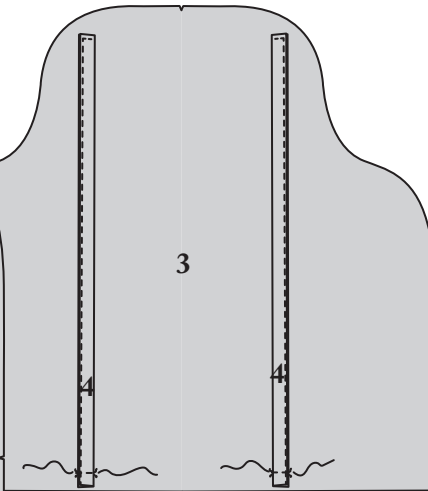

*Shown: Lined version.  
For lined version jump to step 4.*

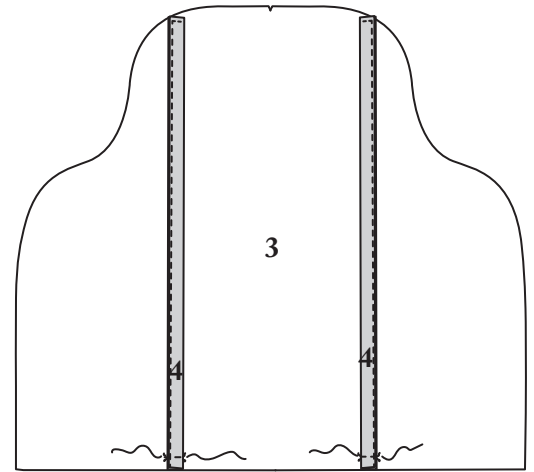

*Shown: Bound versions.  
For bound/lined version jump to step 7.  
For bound/unlined version jump to step 8.*

### BACK TOP HEM

#### (UNLINED VERSION ONLY)

3. From the wrong side of BACK TOP (3) turn up the hem 1cm and press. Then turn up again by 2.5cm and press. Keeping the ties out of the way, edgestitch close to the fold. Press ties down.

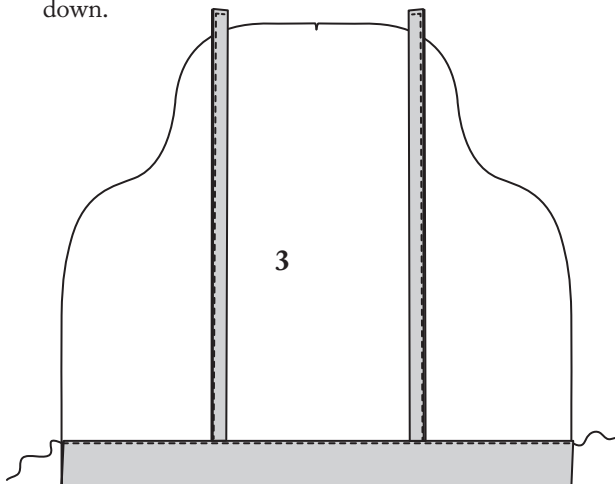

*Shown: Unlined version. For unlined version jump to step 11.*

### ATTACH LINING ON THE BACK TOP (LINED VERSION ONLY)

4. With right sides together, stitch BACK TOP (3) (lining) to BACK TOP (3) (self) at the straight edge, sandwiching in the ties.

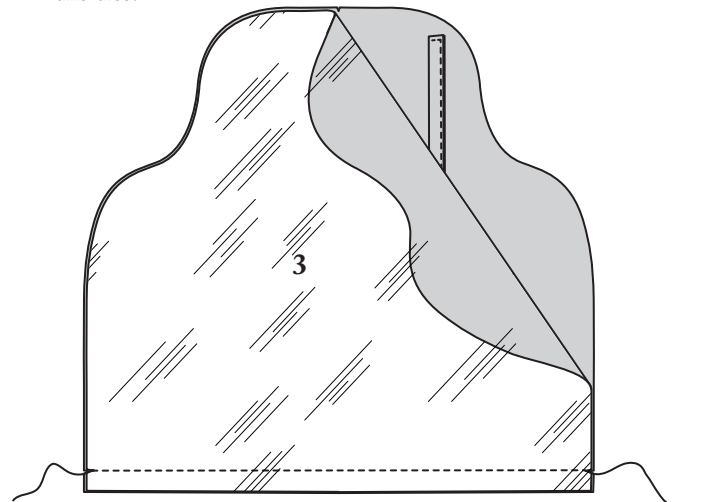

*Shown: Lined version.*

## UNDERSTICH THE BACK TOP (LINED VERSION ONLY)

5. Press the seam towards the lining and understitch.

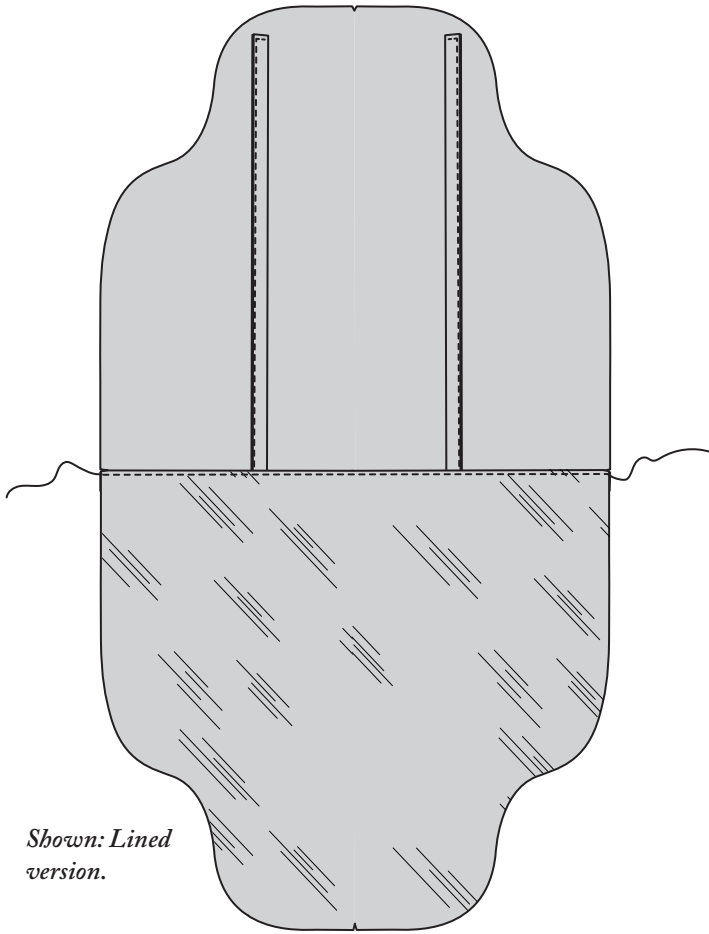

*Shown: Lined version.*

## STITCH BACK TOP LINING TO SELF (LINED VERSION ONLY)

6. Press the lining up to meet the self layer and stitch together around the shaped edge 0.8cm away from the edge.

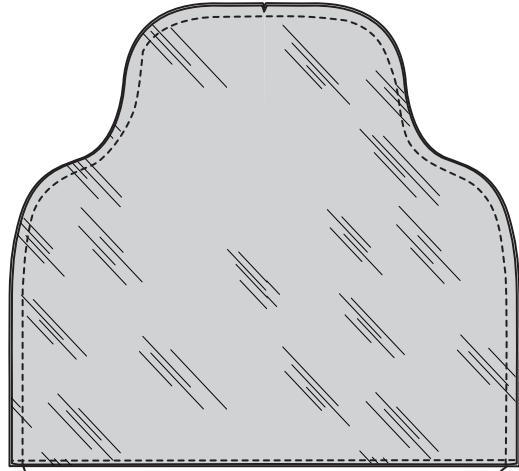

*Shown: Lined version.  
For lined version, jump to step 12.*

## STITCH BACK TOP LINING TO SELF (BOUND/LINED VERSION ONLY)

7. With wrong sides together stitch the lining layer to the self layer 0.6cm away from the edge.

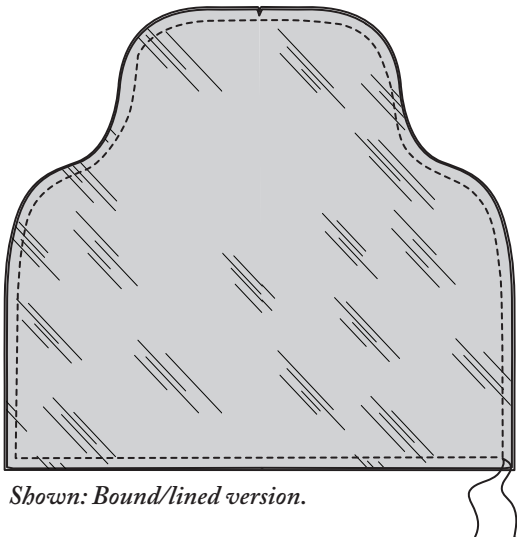

*Shown: Bound/lined version.*

## BIND BACK TOP (BOUND VERSIONS ONLY)

8. With the right sides together, stitch the bias binding (cut to size) to the straight edge of the back top, 0.8cm away from the edge.

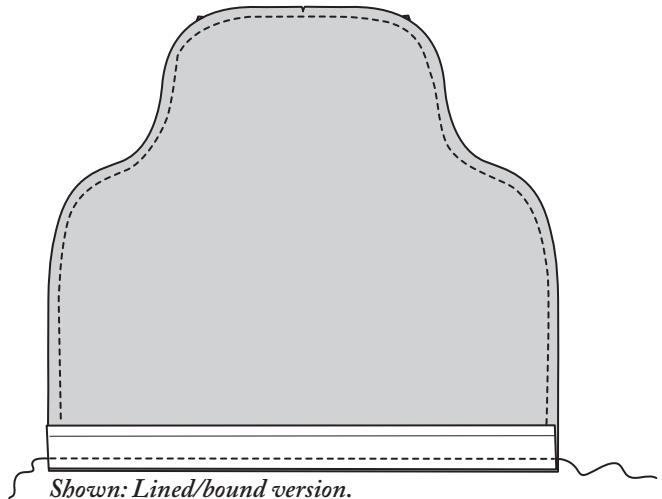

*Shown: Lined/bound version.*



9. Keeping the ties out of the way, bring binding to the back and tack, covering the stitchline.

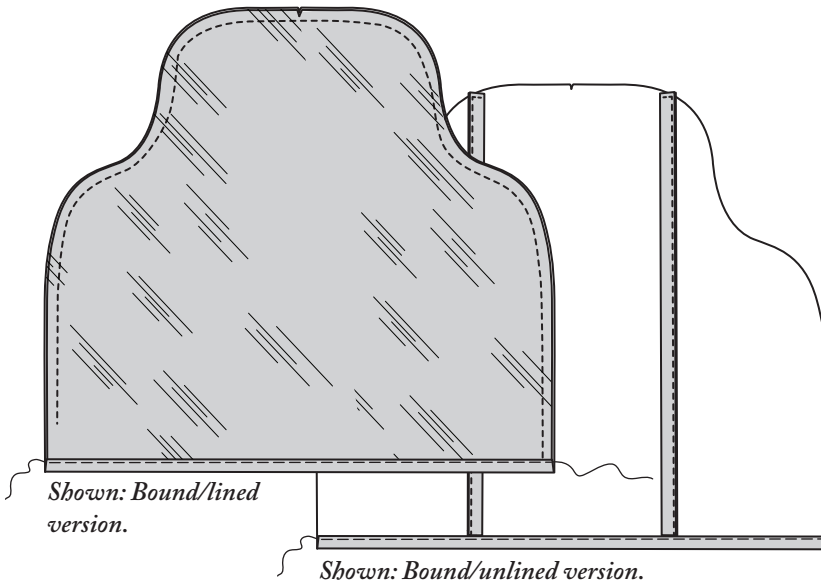

10. Edgestitch the binding from the front, keeping the ties out of the way. Remove tacking. Press ties down.

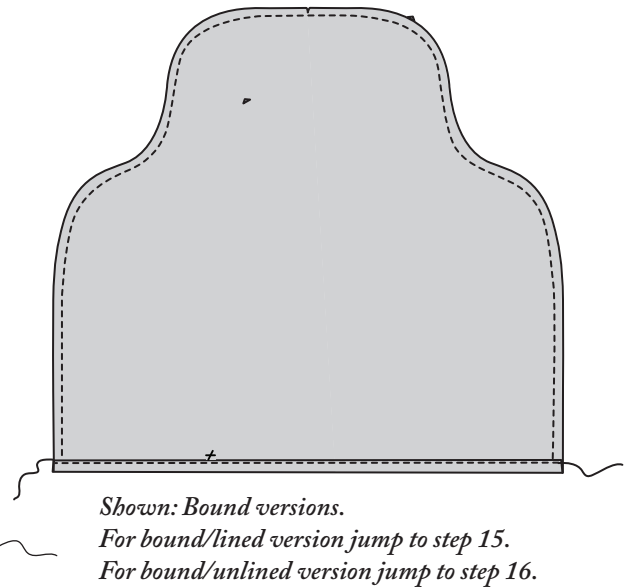

### BACK LOWER HEM (UNLINED VERSION ONLY)

11. From the wrong side of BACK LOWER (2) turn in the hem 1cm and press. Then turn in again by 2.5cm and press. Edgestitch close to the fold.

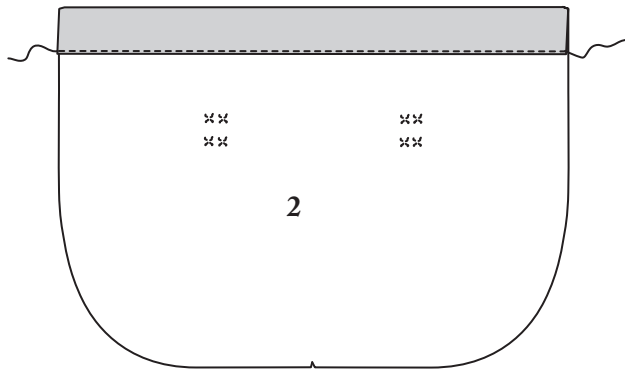

*Shown: Unlined version.*  
*For unlined version jump to step 19.*

### ATTACH LINING ON THE BACK LOWER (LINED VERSION ONLY)

12. With right sides together, stitch BACK LOWER (2) (lining) to BACK LOWER (2) (self) at the straight edge.

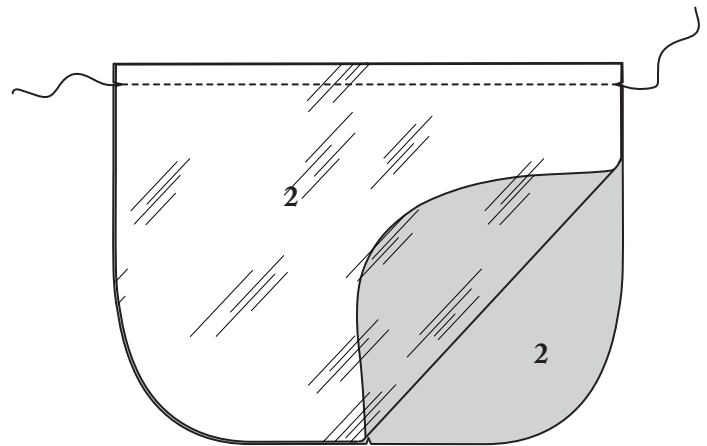

*Shown: Lined version.*

### UNDERSTITCH THE BACK LOWER (LINED VERSION ONLY)

13. Press the seam towards the lining and understitch.

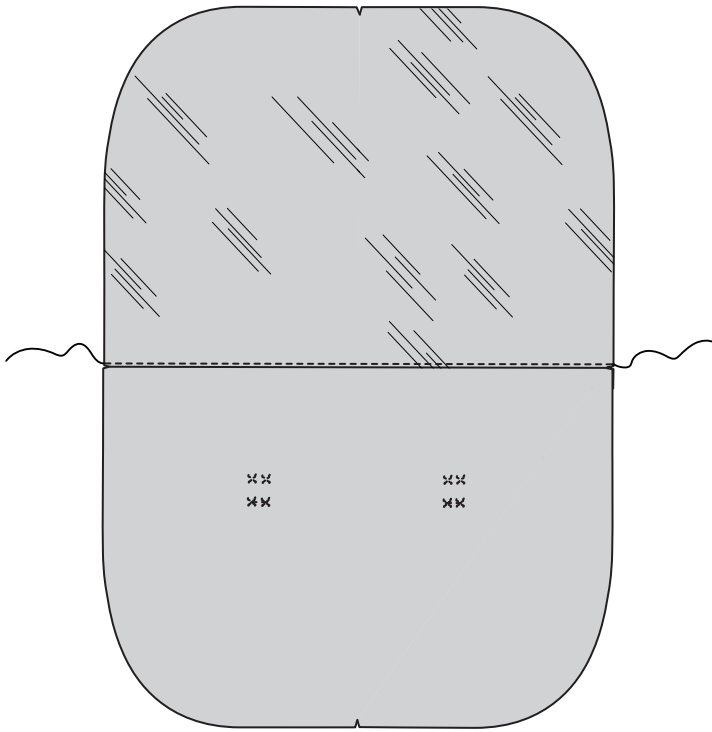

*Shown: Lined version.*

### STITCH BACK LOWER LINING TO SELF (LINED VERSION ONLY)

14. Press the lining down to meet the self layer and stitch together around the shaped edge 0.8cm away from the edge.

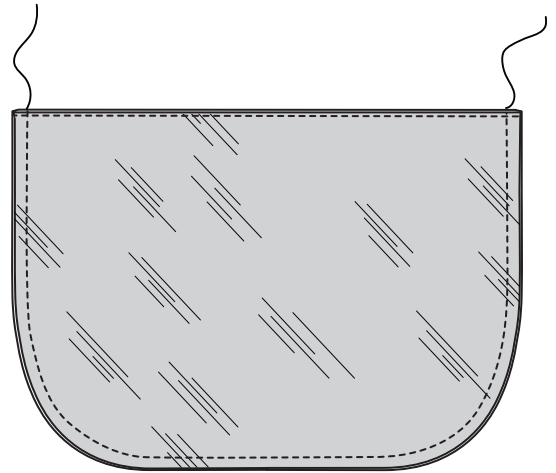

*Shown: Lined version.  
For lined version jump to step 19.*

### STITCH BACK LOWER LINING TO SELF (LINED/BOUND VERSION ONLY)

15. With wrong sides together, stitch BACK LOWER (2) (lining) to BACK LOWER (2) (self) 0.6cm away from the edge.

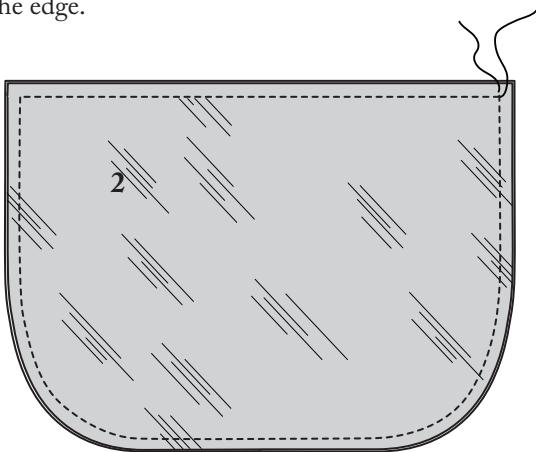

*Shown: Bound/lined version.*

### BIND BACK LOWER (BOUND VERSIONS ONLY)

16. With the right sides together, stitch the bias binding (cut to size) to the straight edge of the back lower, 0.8cm away from the edge.

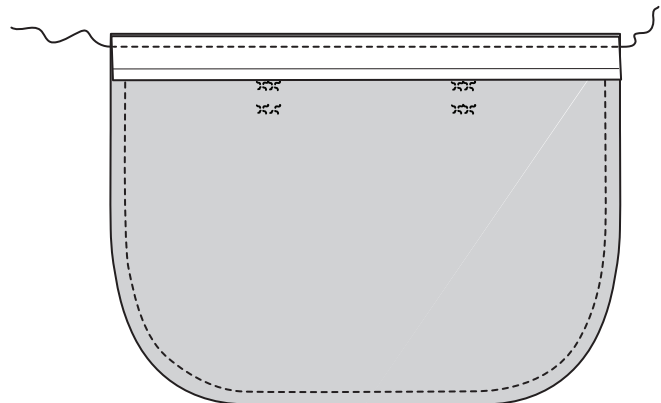

*Shown: Bound/lined version.*

17. Bring binding to the back and tack, covering the stitchline.

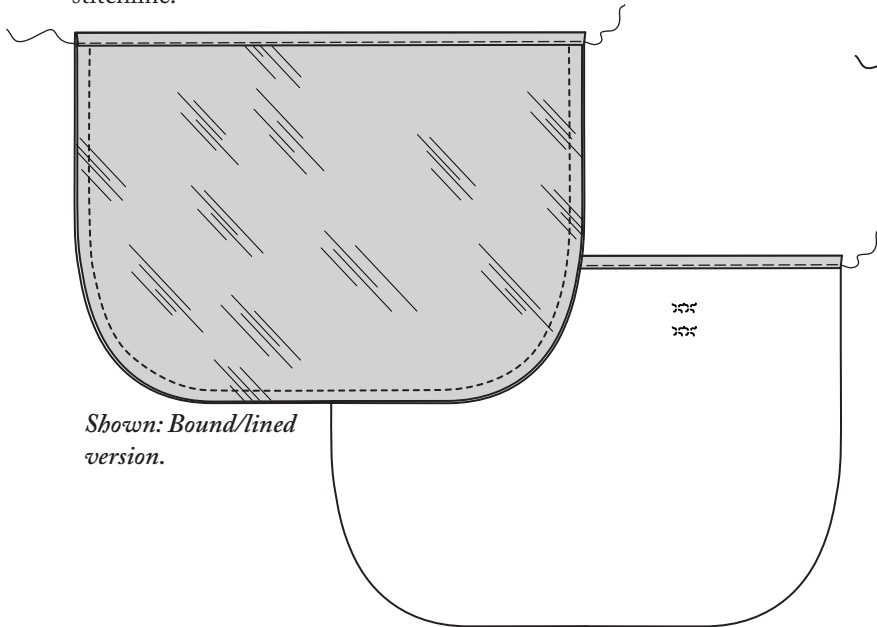

*Shown: Bound/lined version.*

*Shown: Bound/unlined version.*

18. Edgestitch the binding from the front. Remove tacking.

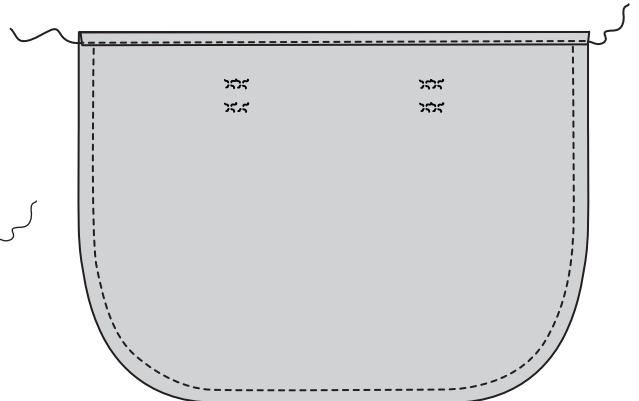

*Shown: Bound/lined version.*

### ATTACH TIES ON BACK LOWER (ALL VERSIONS)

19. With right sides together, place the raw edges of the TIES (4) where indicated by tailor tacks, 0.5cm below the top tailor tacks of the BACK LOWER (2). Stitch.

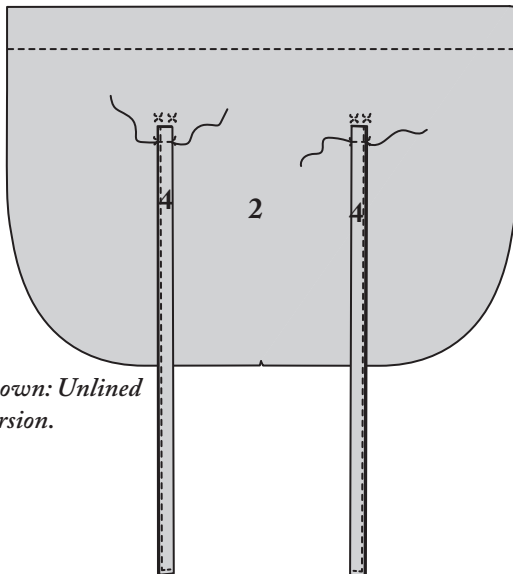
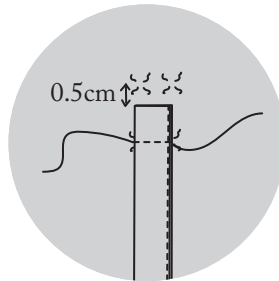

*Shown: Unlined version.*

### REINFORCE TIES ON BACK LOWER (ALL VERSIONS)

20. Press up the ties and stitch through all layers at the top tailor tacks.

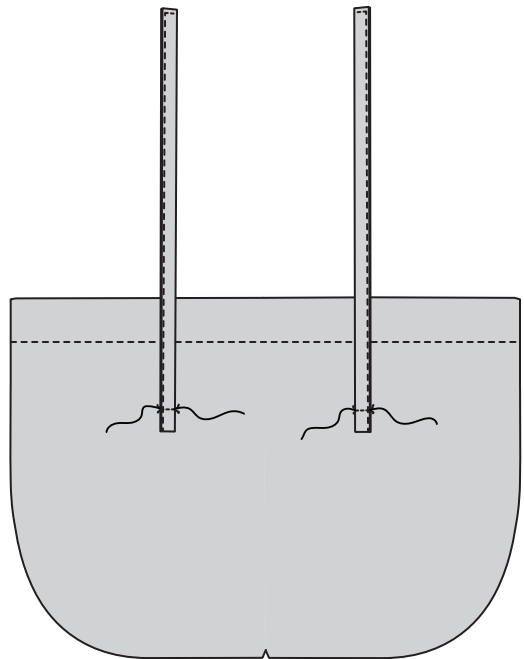

*Shown: Unlined version.*

*For Unlined version jump to step 26.*

## STITCH FRONT LINING TO SELF (LINED VERSION ONLY)

21. With wrong sides together, stitch FRONT (1) (lining) to FRONT (1) (self) and stitch together around the edge, 0.8cm away from the edge.

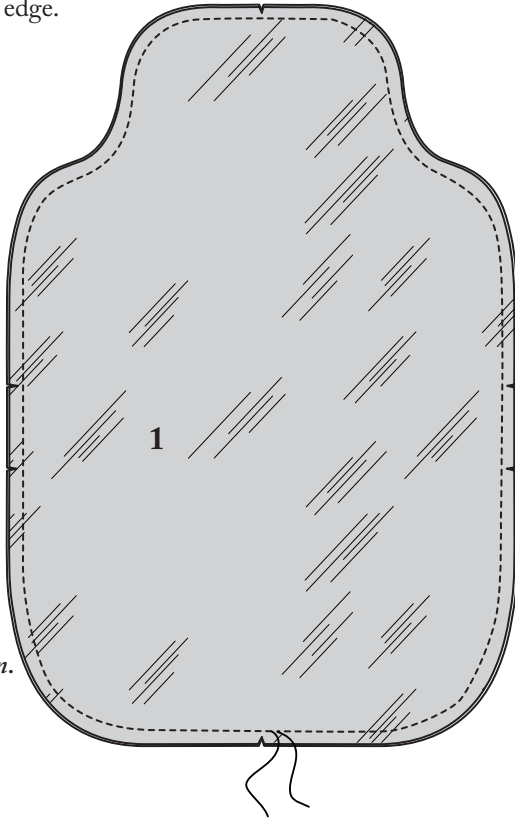

*Shown: Lined version.  
For Lined version  
(unbound) jump to  
step 26.*

## STITCH FRONT TO BACK (BOUND VERSION ONLY)

22. With wrong sides together and matching notches, stitch BACK TOP (3) and BACK LOWER (2) to FRONT (1). Back top sits on the top of the back lower. Stitch together 0.8cm away from the edge.

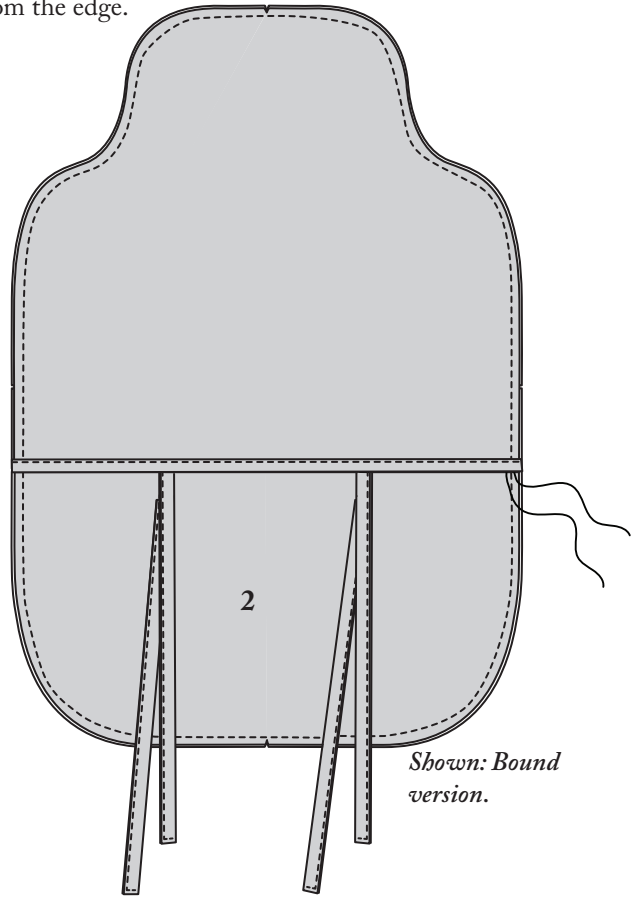

*Shown: Bound version.*

## APPLY BINDING (BOUND VERSION ONLY)

23. Keeping the ties out of the way and with right sides together, stitch the bias binding to the front of the hot water bottle cover, 0.8cm away from the edge.

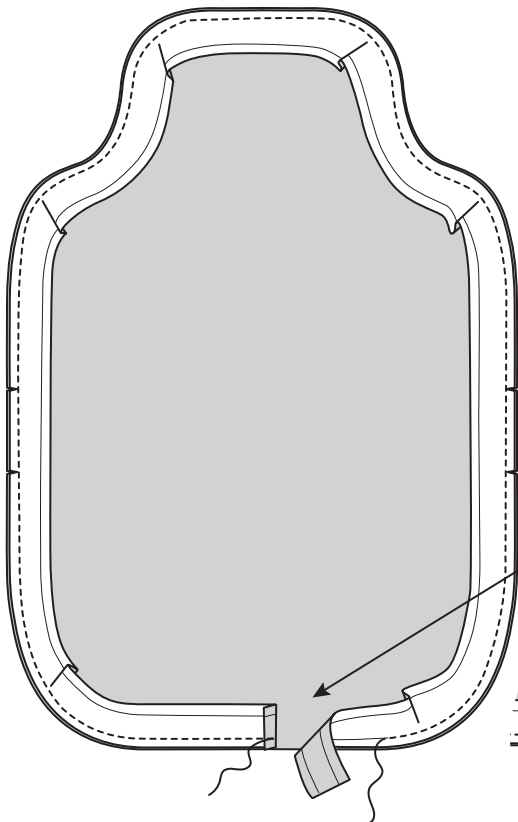

Begin with a fold,  
continue around to  
cover the folded edge.

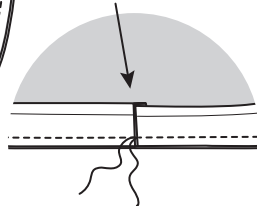

24. Bring binding to the back and tack, covering the stitchline.

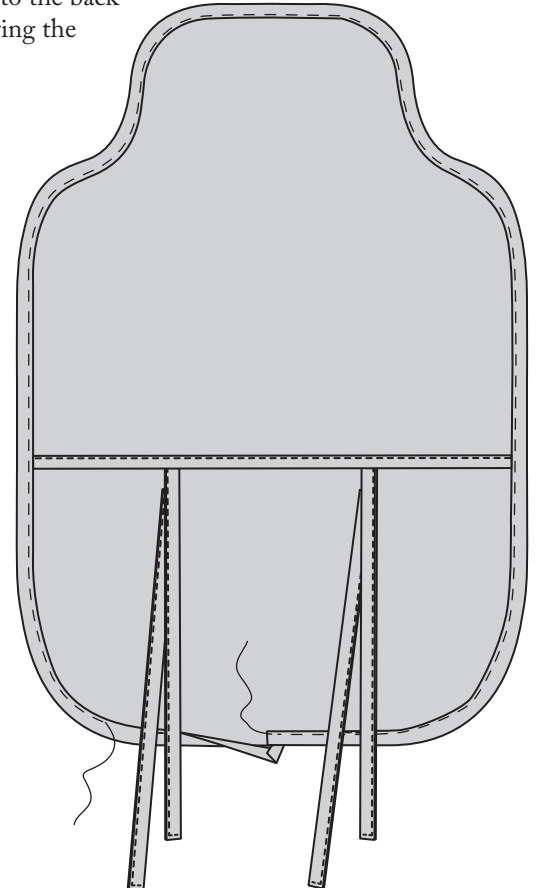

## STITCH FRONT TO BACK (LINED/UNLINED BAGGED OUT VERSIONS )

25. Keeping the ties out of the way, edgestitch the binding from the front. Remove tacking.

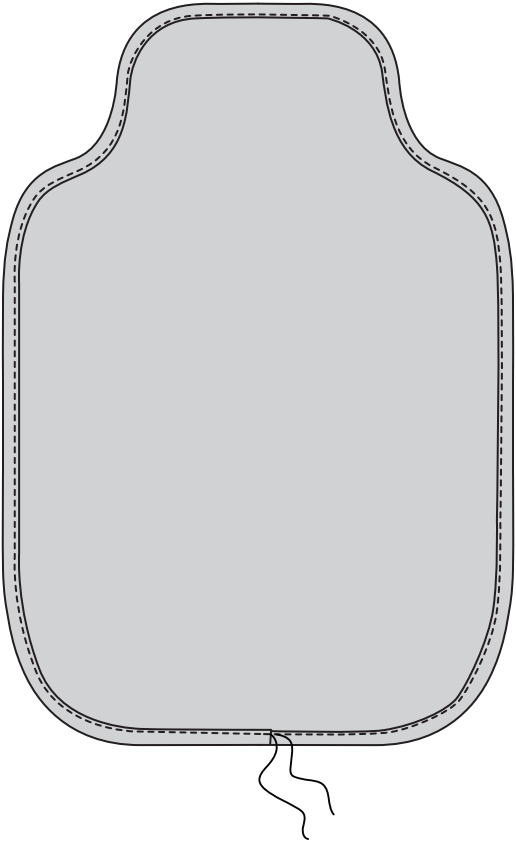

26. With right sides together and matching notches and keeping the ties out of the way, stitch BACK TOP (3) and BACK LOWER (2) to FRONT (1). Back top sits on the top of the back lower (as seen from the right side). Finish edge with an overlock or zigzag.

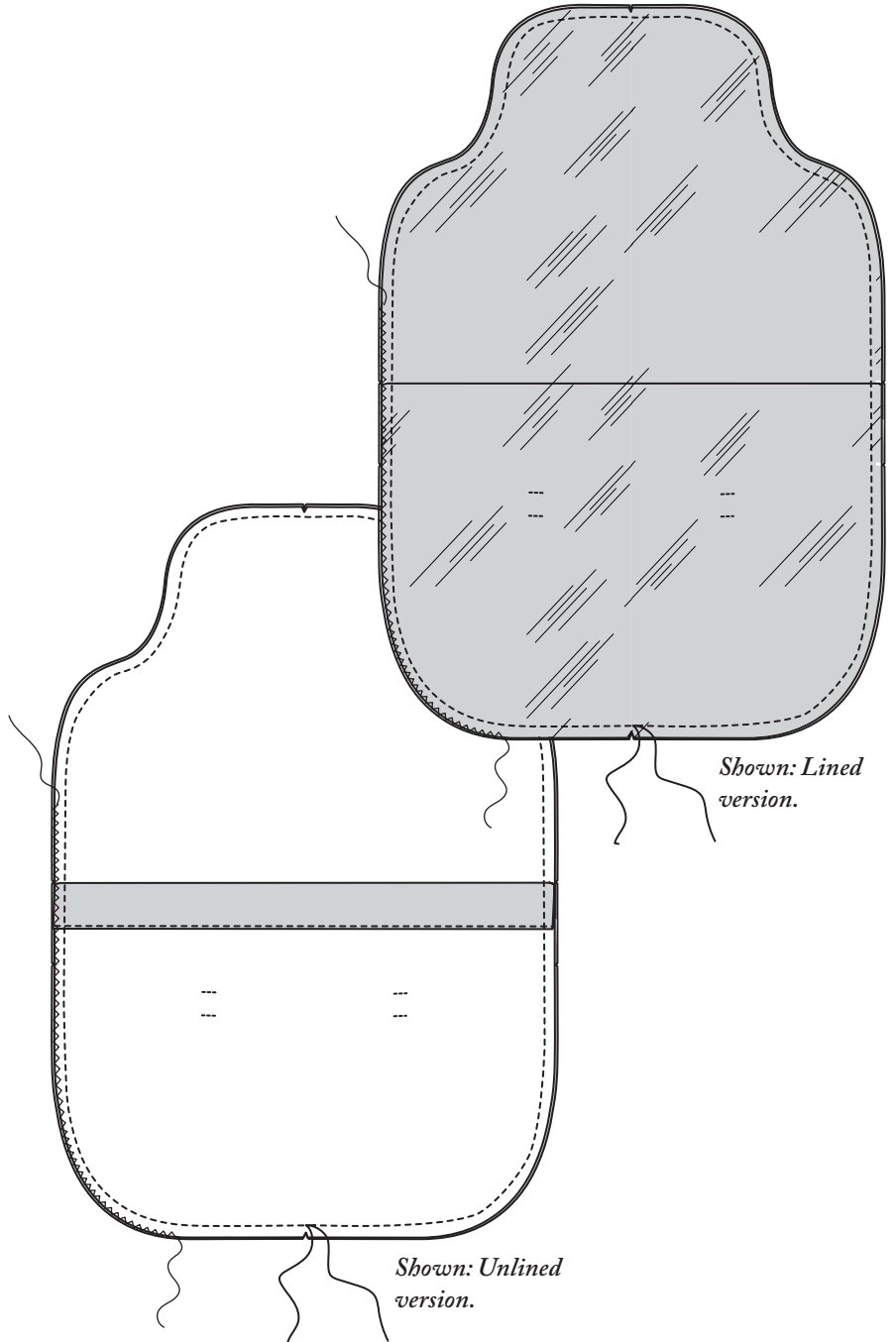

27. **TURN TO RIGHT SIDE**  
Turn to the right side and press.

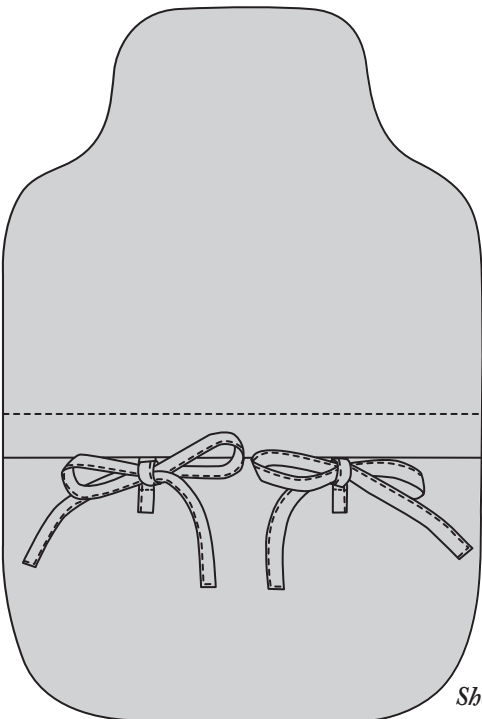

*Shown: Unlined version.*

# 4 PATTERN PIECES

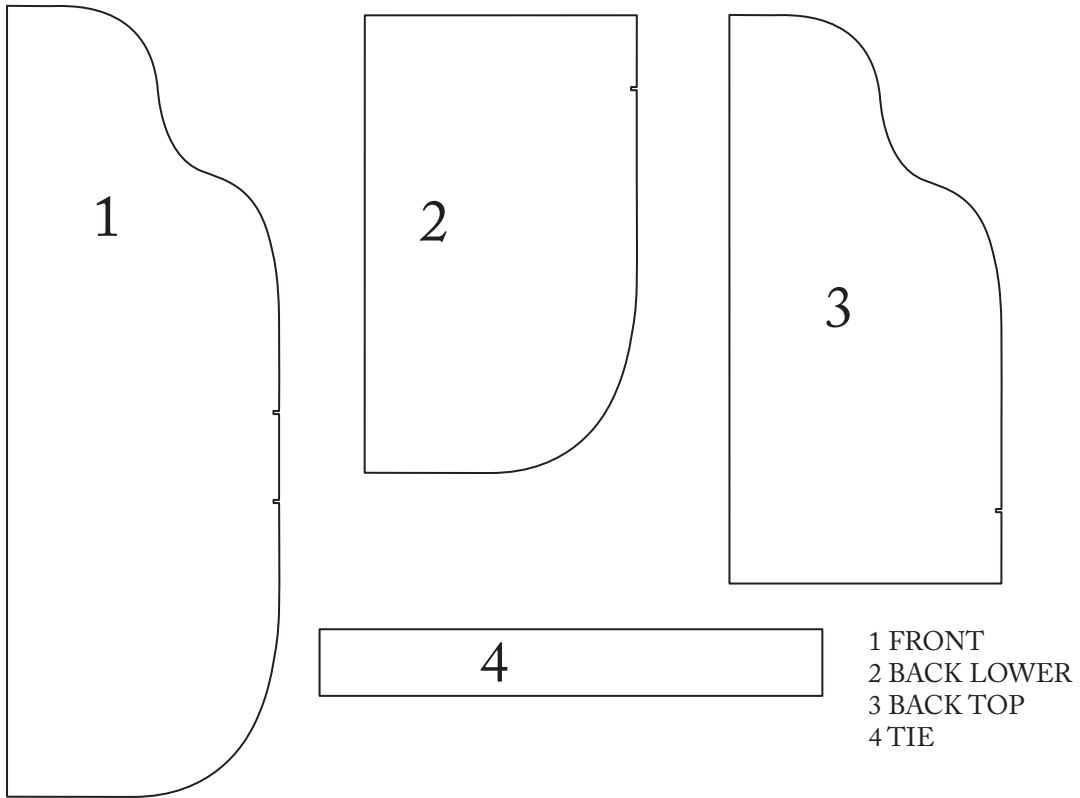

## CUTTING LAYOUTS

RIGHT SIDE OF FABRIC	WRONG SIDE OF FABRIC	RIGHT SIDE OF PATTERN	WRONG SIDE OF PATTERN

## SELF & LINING (OPTIONAL)

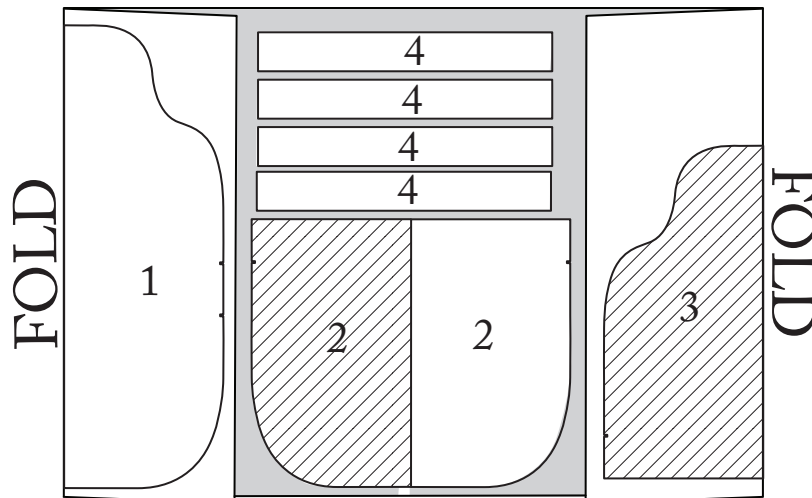

80-150CM WIDE

# PATTERN MARKINGS

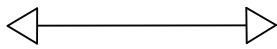

**GRAINLINE:** Place on the straight grain of the fabric, parallel to the selvage. Measure the line at each end of the arrows to make sure it is an equal distance from the selvage.



**FOLDLINE:** Place on fold of fabric. The fold should be on the straight grain, parallel to the selvage.



**NOTCHES AND SYMBOLS:**  
For matching seams and construction details.  
Snip into all notches about 0.5cm before removing the pattern pieces.



This symbol may indicate a balance point to line up seams, position pockets, eyelets and rivets. Mark these points with tailor tacks, chalk or drill holes. **FOR THIS BAG THESE WILL NEED TO BE ACCURATELY MARKED.** (For Oilskin, see tips for oilskin)

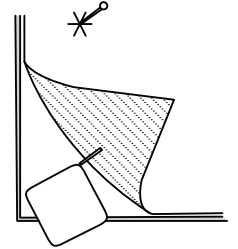
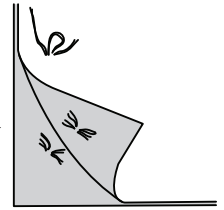

## SEWING INFORMATION

### FABRIC KEY

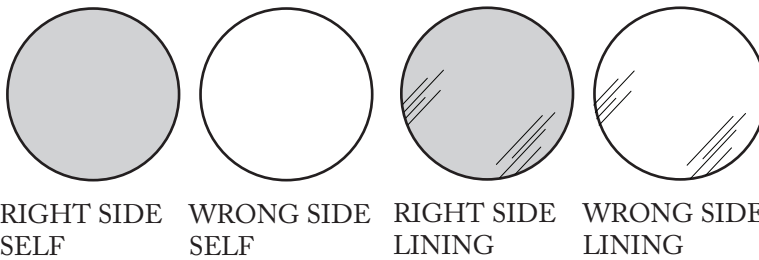

RIGHT SIDE  
SELF

WRONG SIDE  
SELF

RIGHT SIDE  
LINING

WRONG SIDE  
LINING

## GLOSSARY

**SEAMS:** Unless stated otherwise, the seam allowance is 1cm. It is important to match the seam line (stitching line) and not the cut edge as shown here. All seams should start and finish with a backstitch for added strength.

**EDGE STITCH:** A topstitch close to the seam or fold.

**SELF:** Self refers to the main fabric, as opposed to lining and interfacing.

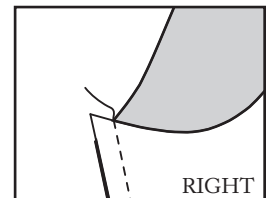
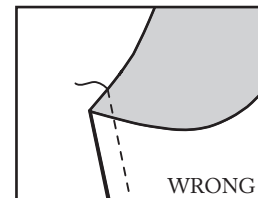

**TRIMMING AND CLIPPING:** Layering the seam allowance. This is done to reduce bulk on a seam that will be enclosed such as a collar facing. The widest part of the seam allowance should be left to the front side of the garment and the trimmed side should be on the inside of the garment. This graded or blended seam will be less bulky. Clipping is used when the seam allowance needs to be spread to the same size as the garment such as on a neck facing.

**FABRICS WITH NAP:** Nap is the pile or direction of the weave, fabrics such as velvet or corduroy have a distinct nap and therefore should be always cut in the same direction.

**SELVEDGE:** The ribbon-like edge which runs along each side of the fabric.

**UNDERSTITCH:** A machine stitch close to the seam and going through all the layers of the seam, used to keep the seam of a facing sitting on the inside of the garment.

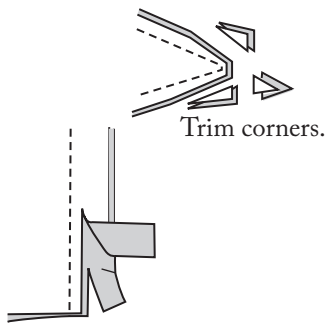

Trim enclosed seams by layering.

# MERCHANT & MILLS

© Merchant & Mills 2023 THIS PATTERN CANNOT BE USED TO MAKE HOT WATER BOTTLE COVERS FOR SALE OR TRADE.

The Copyright law allows the customer to employ a seamstress to make this pattern, but it cannot be used in any sort of commercial production. Copyright law is very specific and will judge on what has remained the same rather than what has changed.